

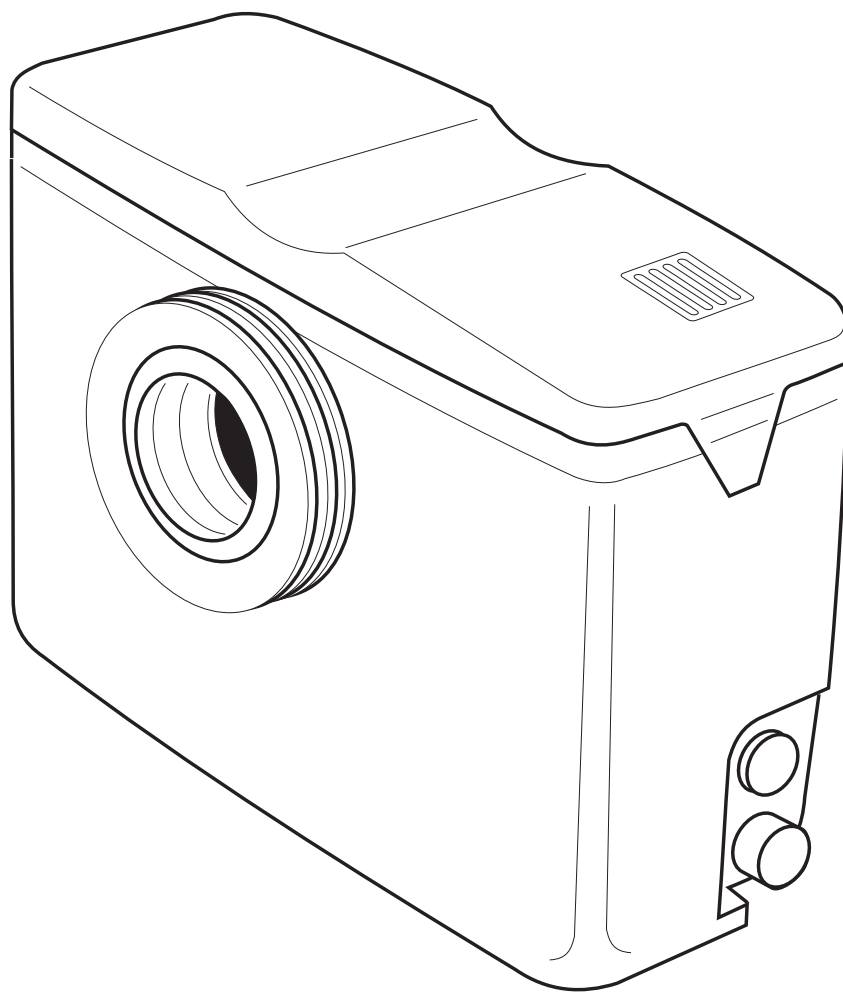

INSTALLATION AND OPERATING GUIDELINES











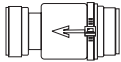

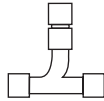

HELPLINE 01442 211554

Product Summary

The Powerflush™ is a fully automatic pump unit specifically designed for pumping away effluent from a complete bathroom where gravity drainage is impossible or uneconomical. The unit is suitable for installing either at the initial building stage or for retro fitting to existing buildings and can accept waste connections from a toilet, basin, shower or bidet.

The Powerflush™ shreds faecal effluent and allows it to be pumped through 32mm waste pipe. It is important to note that the Powerflush™ is not a sanitary disposal unit.

	Ref.	Description	Illustration	Qty.
Parts supplied	A	Powerflush™ Macerator		1
	<hr/>			
Fittings supplied	B	Non-return Valve (discharge)		1
	C	Hose Clamp		3
	D	Rubber Blanking Cap		1
	E	Dowel Floor Fixing		2
	F	Fixing Screw		2
	G	Ground Fixing		2
	H	Swept Tee-Piece with Air Admittance Valve		1
	I	Straight Coupling		2
	<hr/>			
Fittings required (not supplied)	J	Solvent Cement		1
	K	Unswitched 5 amp Fused Wiring Connection		1
	L	32mm Waste Pipe		To fit
	M	Pipe Clips		To fit
<hr/>				
Tools required (not supplied)		Cross Head Screwdriver		
		Electric Drill with 6.5mm Drill Piece and Flat Head Screwdriver Piece		

Before you start

- Check the packaging and make sure you have all the parts and fittings listed above. If not, contact your local stockist who will be able to help you.
- When you are ready to start, make sure that you have the right tools to hand, plenty of space and a clean dry area for assembly.
- Plan out your installation before commencing work. Take into account all incoming and discharge pipe work, access for maintenance and also the position of any additional appliances to be served by the Powerflush™.

Assembly

IMPORTANT Ensure that you have read and understood the Installation and Operating Guidelines fully before commencing work. Should you have any queries please contact the Help Line on (01442) 211554.

1. Siting the Powerflush™

- 1.1 Decide on the location of the Powerflush™ (A). The unit is designed for a direct toilet connection and so should be positioned behind the toilet on a firm level surface resistant to any condensation. (See Fig. 1)

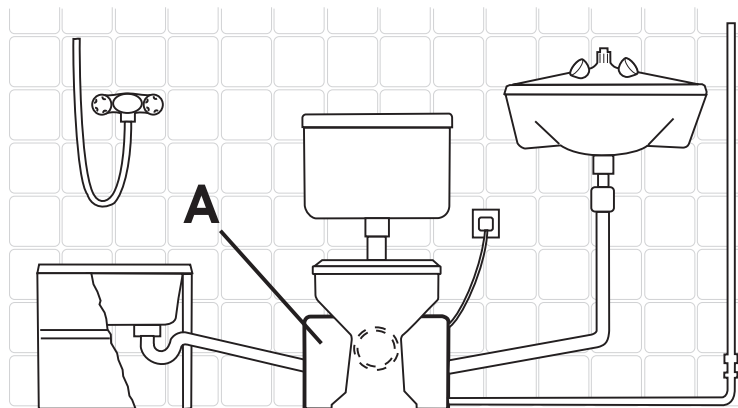

Fig. 1

- 1.2 The Powerflush™ should be sited with access in mind in the event of maintenance being required.
- 1.3 Position the Powerflush™ and fix to the floor using the Dowel Floor Fixings (E), Fixing Screws (F) and the Ground Fixings (G). (See Fig. 2)

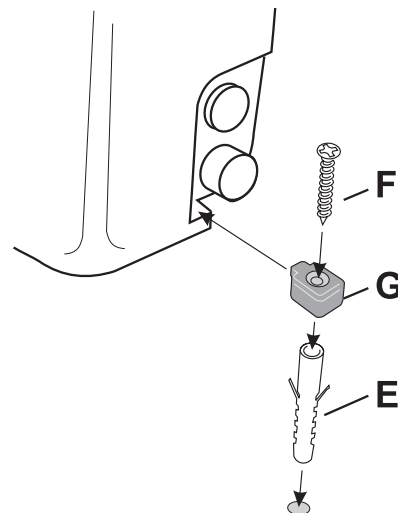

Fig.2

2. WC Inlet Connection

Position the toilet in front of the Powerflush™ (A) and pull the black rubber sealing sleeve directly onto the toilet outflow pipe ensuring as much of the outflow pipe as possible is covered by the sleeve. (See Fig. 3)

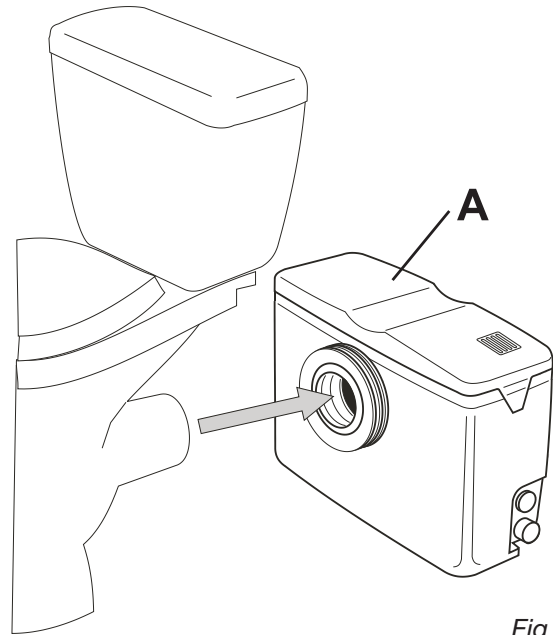

Fig. 3

3. Discharge Connection

3.1 The discharge line can be connected to either the left or the right hand side of the Powerflush™ as required. The discharge port not being used needs to be sealed off using the Rubber Blanking Cap (D) and fixed into place using a Hose Clamp (C). (See Fig. 4)

3.2 The Non-return valve (B) should be fitted directly to the discharge line and fixed into place using the Hose Clamp (C). (See Fig. 4)

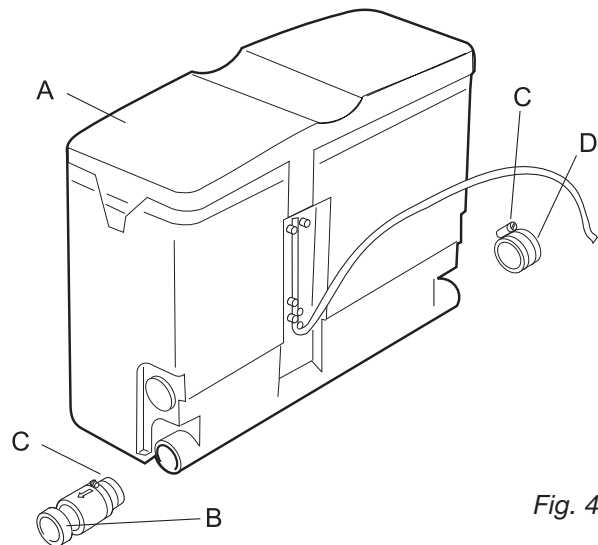

Fig. 4

3.3 When fitting the Non-return Valve (B) the flap must hinge at the top with the arrow pointing down. The arrow on the outside of the Non-return Valve should point in the direction of the flow. (See Fig. 5)

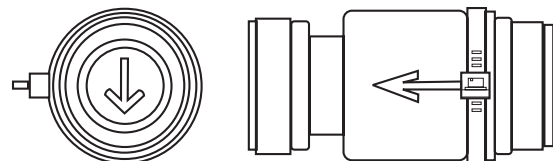

Fig. 5

- 3.4 The discharge pipe work should be 32mm Waste Pipe (L) and all joins should be made using Solvent Weld (J), under no circumstances should push-fit or compression fittings be used. The Powerflush™ is designed for one vertical lift only and this lift should be within 500mm of the Non-return Valve (B). It is important to remember that you must NOT pump down before pumping vertically as this will significantly reduce the distance the Powerflush™ can pump. Push the 32mm Waste pipe (L) into the Non-return Valve (B) and fix securely into place using a Hose Clamp (C). The pipe work should be fixed to the wall using Pipe Clips (M) to prevent any movement under pressure. (See Fig. 6)

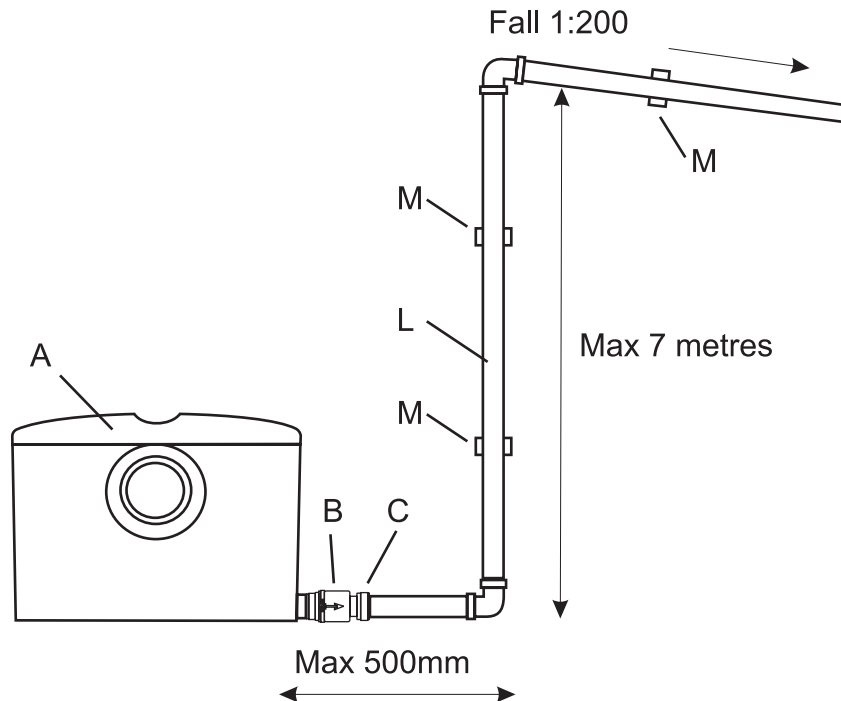

Fig. 6

ATTENTION It is recommended that there are no bends in the vertical lift, however if this is unavoidable a minimum of slow radius bends may be used. It is also advisable to take the vertical pipe work to the highest possible point, giving as much of a downwards gradient towards the discharge point.

- 3.5 The Swept Tee-piece with Air Admittance Valve (H) should be installed at the beginning of the horizontal run after the vertical lift (See Fig. 7) to avoid siphoning within the pipe work. To install the Tee-piece, you will need to cut the Waste pipe and trim down any excess plastic. Apply Solvent Cement to the inside of the Tee-piece and push into place over the Waste Pipe.

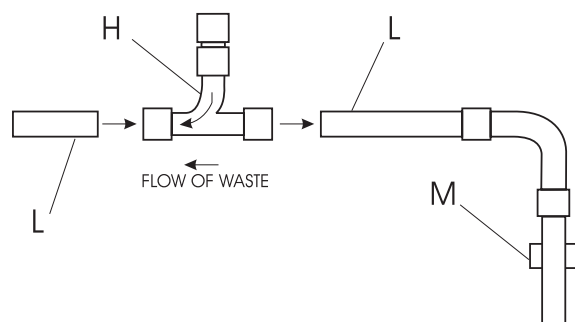

Fig. 7

ATTENTION The Swept Tee-piece should be installed with the sweep going against the flow of waste. (See Fig. 7)

3.6 After the Air Admittance Valve run the horizontal pipe to the discharge point on a downwards gradient (1:200) using as few bends as possible. Connection to the sewage system should be into the soil stack via a branch pipe, a strap on boss or an integral boss on an existing fitting.

4. Connection of Additional Appliances

The Powerflush™ comes provided with two low level inlets for connection of a basin, shower or bidet and are positioned on either side of the unit at 74mm from floor to centre. The inlet comprises of a push in seal with Non-return Valve and a blanking cap. To utilise the inlet you must first remove the plastic blanking cap to expose the rubber seal (See Fig. 8a). Make sure that the position of the seal is such that the letters OBEN are at the top of the seal and then push into place the 40mm waste pipe from the basin, shower, etc. If the inlet pipe is 32mm then you must push the Straight Coupling (I) into the seal (see Fig. 8b) and Solvent Cement to fix the Waste Pipe. The fall required for incoming pipe work from additional appliances should be 1:40 and when connecting a shower to the Powerflush™ the shower tray must be at least 150mm from the floor.

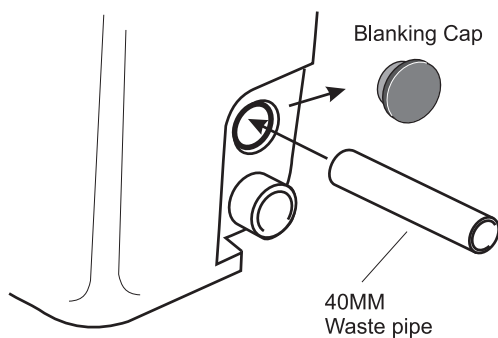

Fig. 8a

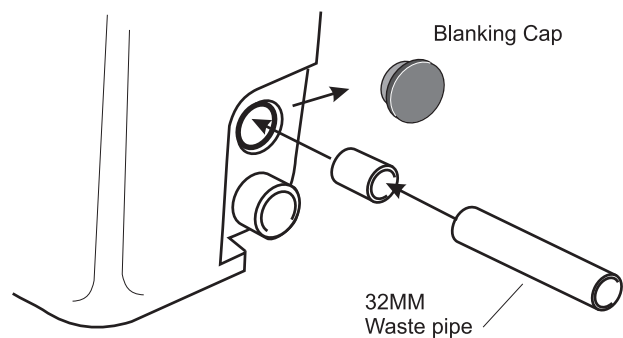

Fig. 8b

ATTENTION Check the operation of the inlet Non-return Valve ensuring it is not infringed by the incoming pipe work.

5. Venting

The venting of the unit can take place into the room via the activated carbon filter (supplied as standard). A separate vent line brought above roof level can be fitted by removing the plastic grill and inserting a 25mm pipe. (See Fig. 9).

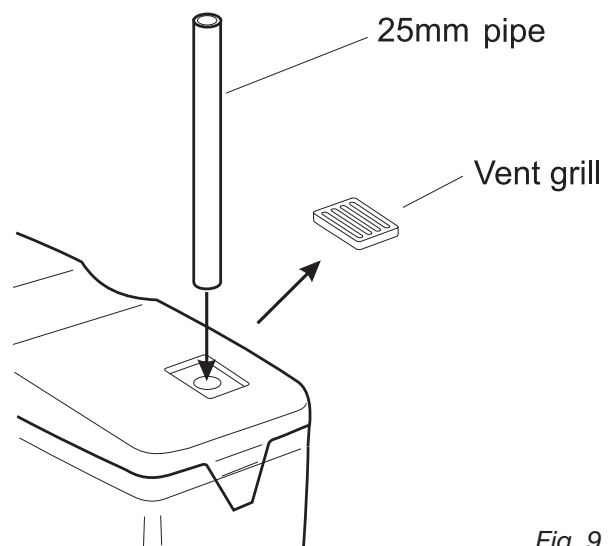

Fig. 9

6. Electrical Connection



Please refer to the 'Safety and Building Regulations for Maintenance, Inspection and Installation Work' section in these guidelines prior to commencing electrical work. (Refer to page 9)

ATTENTION Before connection of the unit, a qualified person should ensure that one of the necessary electrical protection devices is present. Earth line, earth leakage, circuit breaker, etc. should comply with the regulations of your local Electricity Board.

The Powerflush™ should be connected to an Unswitched 5Amp fused wiring connector (See Fig. 10)

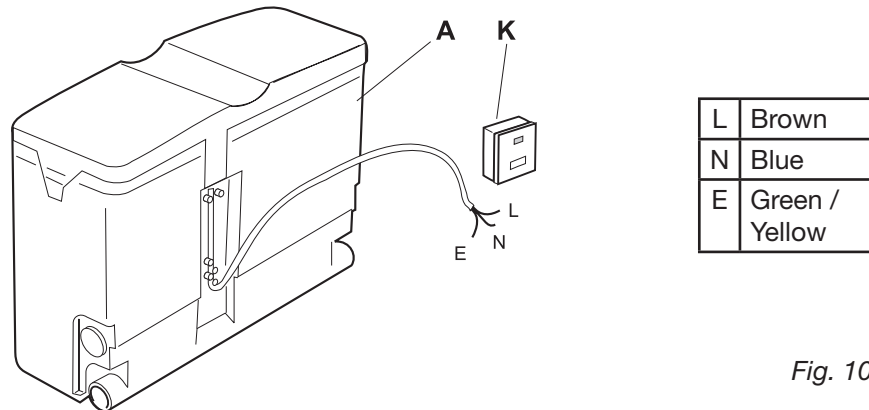

Fig. 10

NOTE The wiring connector should be located in a dry area.

7. Commissioning

It is essential to check the operation of the Powerflush™ prior to use. Particular attention should be paid to the following:

- Is the tank cover in place on the unit?
- Has the electrical connection been made in accordance with regulations?

Now flush the toilet once and check to see that the WC discharge is being pumped away sufficiently and that there are no leaks at any point in the incoming and discharge pipe work.

Care and Use

- It is recommended that the Powerflush™ be flushed through every two weeks using standard domestic bleaches, W.C. cleansers, etc. This will help to break down any build up of solids within the Powerflush™ tank.
- Do not flush any aggressive chemicals such as acids, caustics, solvents etc. into the Powerflush™.
- To avoid the build up of limescale in the unit, use the following procedure:
 - Disconnect the power supply to the Powerflush™
 - Pour 3-4 litres of water mixed with a strong solution of descalent/spirit of salts into the W.C. pan.
 - Leave it to stand for 1-2 hours and then reconnect the power supply.
 - Flush the W.C. several times to clear.

The frequency of this operation will depend on the hardness of water in your locality. We would recommend that this procedure is followed at least twice a year.

ATTENTION The water authorities strongly discourage the disposal of sanitary items such as condoms, tampons and sanitary towels via a W.C.

The following items must NOT be disposed of into the Powerflush™:

- Cotton Wool Buds
- Baby Wipes
- Any hard objects, i.e. wood, metals, plastics etc.
- Any fibrous materials such as cloths, rags, etc.
- Or Similar

Maintenance

1. Steps to be taken should a fault occur.

- Water sources that drain into the Powerflush™ should not be used.
- Disconnect the Powerflush™ from the mains supply and take steps to ensure it cannot be inadvertently turned back on.

2. The Powerflush™ does not function and the motor is silent.

- Turn off power supply and wait approximately 30mins.
- After 30 mins period turn the power supply back on.

If after this period the Powerflush™ does not function correctly then turn off power supply and contact the Help Line on (01442) 211554.

3. The Powerflush™ does not function and the motor makes a humming noise.



The motor may be hot so handle with care.

- Withdraw power supply and ensure that it cannot be inadvertently turned back on.
- Pull the latches on the tank cover and release the lid. (See Fig. 11)
- Unscrew Rotor cap on top of motor housing (See Fig.11) to expose the top of the rotor shaft.
- Use an electric drill to rotate the rotor shaft and clear any blockages. (See Fig 12)
- Screw the Rotor cap back into the top of the motor housing and replace the lid.
- Reinststate the power supply and test the unit.
- If the Powerflush™ still does not function correctly please contact the Help Line on (01442) 211554.

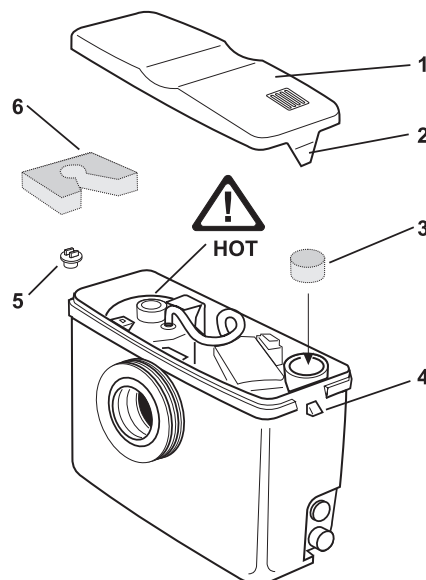

PART No	DESCRIPTION
1	LID
2	LATCHES
3	CARBON FILTER
4	TANK LATCHES
5	ROTOR CAP
6	FLOATATION PREVENTION DEVICE

Fig. 11

4. Changing the Carbon Filter.

 The motor may be hot so handle with care.

NOTE Changing the carbon filter is only necessary if the Powerflush™ begins to emit odours.

- Pull the latches on the tank cover and release the lid. (See Fig. 11)
- Change the carbon filter on top of the Electrical assembly. (See Fig. 11)
- Replace the lid.

5. Removal of the Powerflush™.

 The motor may be hot so handle with care.

- The tank must be emptied prior to disconnecting the discharge and inflow pipe work.
- To empty the tank remove the lid and unscrew the cap on top of the motor housing exposing the top of the rotor shaft. (See Fig. 11)
- Using a screwdriver rotate the rotor shaft until the tank is empty. (See Fig. 12)
- Screw the cap back on top of the motor housing and replace the lid.
- Dismantle the discharge and inflow lines.

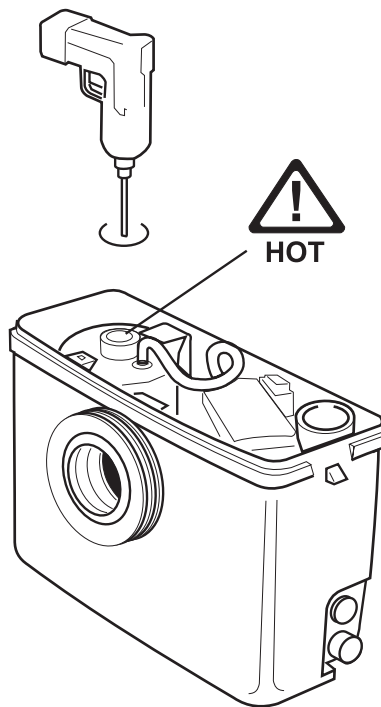

Fig. 12

Safety and Building Regulations for Maintenance, Inspection and Installation Work

These operating and operating guidelines contain basic information on the installation, operating and maintenance and should be followed carefully. For this reason it is essential that these guidelines are carefully read before erection or commissioning by both the installation crew as well as those responsible for operation or maintenance. The operating guidelines should always be readily available at the location of the unit.

In addition to following the safety regulations of a general nature listed under these main headings, it is also essential that the special safety instructions given under other headings be observed.

Identification of hints in the operating guidelines



Safety instructions given in this operating manual, the non-observance of which could cause danger to life have been specifically highlighted with the general danger symbol.



The presence of a dangerous voltage is identified with the safety symbol.

ATTENTION Applies to safety instructions, the non-observance of which could damage the unit or effect it's functioning.

Symbols directly on the unit itself, e.g.

- Direction of rotation arrow
- Nameplate must be carefully observed and must be maintained in a legible condition.

Dangers which could arise due to non-observance of the safety instructions

The non-observance of the safety instructions can lead to both dangers to personnel and also to possible harm to the environment or the unit itself. Non-observance of the safety instructions can invalidate the rights of the user to any compensation or regress.

In detail, non-observance can for example result in the following dangers:

- Failure of important functions of the unit/installation
- Danger to personnel by electrical, mechanical or chemical influences
- Danger to the environment by leakage of dangerous substances

Carrying out work in a safety conscious manner

The safety instruction listed in this operating manual, the existing National Regulations for safety, as well as any internal operating or safety regulations which apply in the user's own premises must be observed.

Safety Regulations for the Owner/Operator

All dangers due to electricity must be avoided (for details consult the Regulations of your local Electricity Supply Company).

Safety Regulations for maintenance, inspection and installation work

The user of the unit should ensure that all maintenance, inspection or installation work is carried out by authorised and qualified skilled personnel. The user must also make certain that they have carefully studied the operating guidelines. In principle all work on the unit should only be carried out while it is stationary. Pumps or units, used for pumping of fluids which could be injurious to health must be decontaminated. After completion of the work all safety and protective devices must be refitted and a check should be made that they are fully functional. Before starting up again, the points listed under the section 'Commissioning' should be complied with.

Unilateral modification and spare parts manufacturing Modifications or changes to the unit/installation should only be carried out after consultations with the manufacturer. Original spare parts and accessories authorised by the manufacturer are essential for compliance with safety requirements. The use of other parts can invalidate any claims for warranty or compensation.

Unapproved usage

The operating safety of the unit is only guaranteed provided that the unit is used in accordance with the technical section within these guidelines. The limit values given in the data sheet should under no circumstance be exceeded.

IMPORTANT As of 1 January 2005, changes to the Building Regulations affect domestic electrical installations in England and Wales.

You do not need to be a qualified electrician to make changes to your homes electrical system, but the work must be done in accordance with standard on the regulations.

You do not need to call your local authority if you do minor electrical work such as:

- replacing or repairing a socket, light or cable in any room.
- adding extra spurs, sockets or lights to an existing circuit (except in a kitchen, bathroom or outdoors).
- however the work must be done to the standard in the wiring regulations and you should consider having the work checked by a competent electrician to make sure it is safe.

Before you start electrical work such as

- adding new circuits to your installation
- any work (other than repair/replacements) in a room where there is water (e.g. kitchen, bathroom etc).
- any work (other than repair/replacements) outdoors (e.g. installing garden lighting or sockets etc.)

You must notify you Local Building Control Department, which has responsibility for ensuring the work is tested and inspected.

Where you have work done by an electrician who is a member of a competent person self-certification scheme, the electrician will be able to certify the work complies with the Building Regulations and you do not need to notify your local authority.

We recommend that you make yourself aware of the regulation before you undertake any work and if you require any clarification contact your Local Authority Building Control Department.

Technical specifications

Electrical Details

Application	1 x W.C., 1 x Basin, 1 x Shower or Bidet
Type	Powerflush™
Maximum Vertical Lift	7 metres
Voltage	220/240v
Frequency	50Hz
Motor Power (P1)	1.1 kW
Rated Current	4.7amps
Degree of Protection	IP44
Cable Length	2 metres
Weight	9 kg
Discharge Connection	32mm

ATTENTION Only installations conforming to the above specification are acceptable.

Pump Performance

Head H (m)	1	2	3	4	6	7
Flow Q (m³/h)	7,0	5,8	5,0	4,7	4,3	3,6
Flow Q (l/s)	2,0	1,6	1,4	1,3	1,2	1,0

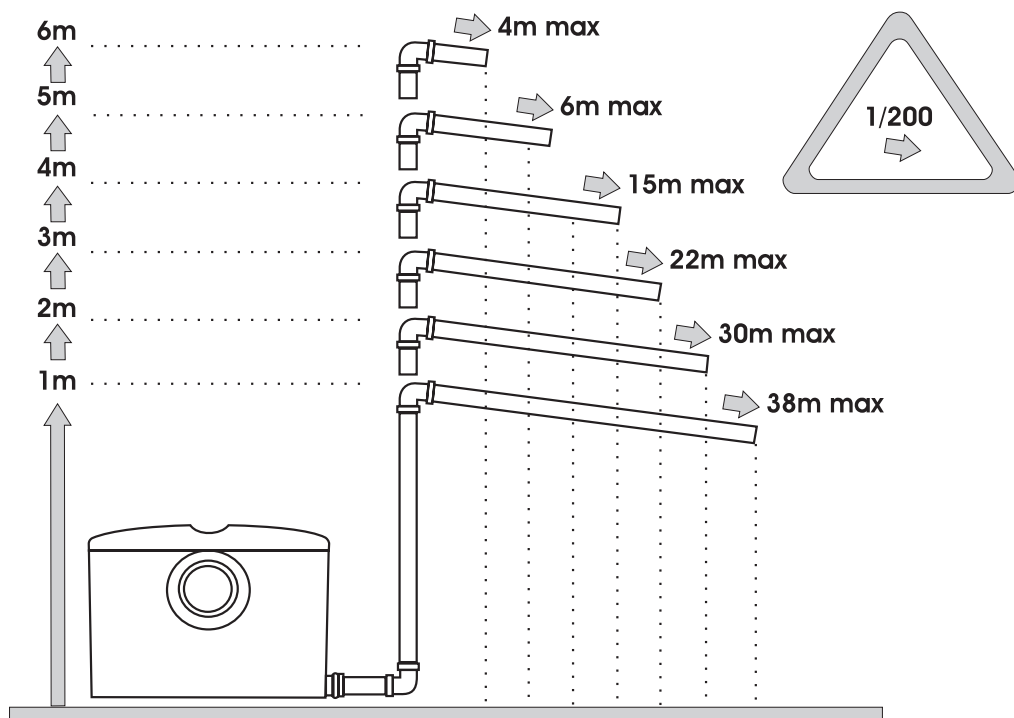

Dimensions

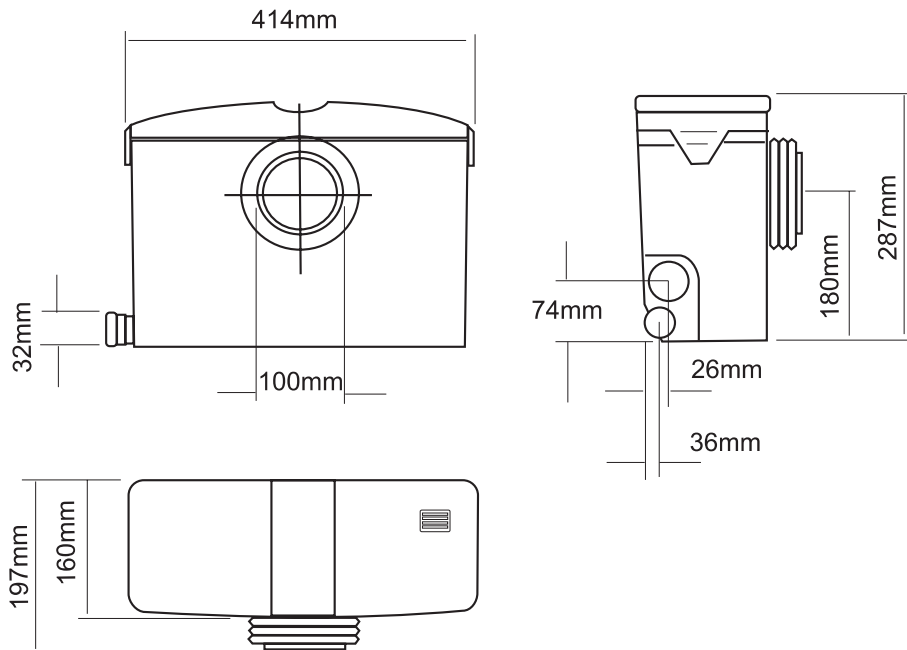

ATTENTION The Powerflush™ conforms to EN 12050-3 lifting plant for wastewater containing faecal matter for limited applications.

Guarantee

12 month component guarantee.

If within the guarantee period of a product any defect is discovered in respect of workmanship, construction or material, we will make good the defect or replace the defective part at our expense inside normal working hours at the company's premises providing, written notice is given immediately the defect is discovered and that, if required by us, the part or complete unit is returned to the company's premises carriage paid. Spares or repaired parts are delivered ex works exclusive of fitting. The guarantee does not apply to defects caused by incorrect installation, abnormal conditions of working, accidents, misuse or neglect. Our responsibility is in all cases limited to the cost of making good the defect or replacing the defective part at the company's premises inside normal working hours. We exclude all liability for any consequential or other damage or losses which may occur. We will not be liable if the pumping system fails due to it having been incorrectly specified.

Wykamol Group

Unit 3 Boran Court
Network 65 Business Park
Hapton, Burnley
Lancashire BB11 5TH

Tel: 0845 400 6666
Fax: 0845 400 3333
Email: sales@lectros.com
Web: www.wykamol.com

